



Portfolio #1

**Bronze & Steel
Tables & Pedestals
by DAVID ORTH**

*David Orth
Orth Sculpture
5181 E. Wyman Road
Fayetteville, Arkansas 72701
708-288-5199 voice or text
davidorth@OrthSculpture.com
www.OrthSculpture.com*

Testimonials & Reviews

"... an articulate, loving sense of craftsmanship drawn from the past ... sustained conceptually by...humor and personal vision ... highly sensual ... finely tuned ... consistent ... truly 'art furniture.'"

- The New Art Examiner

"Orth's art is amazing...overwhelming...the primal versus the ethereal. Rock and roll...the blues...arias."

- James A. Mangum, author of the Dos Cruces Trilogy

"fabulous ... mess-with-your-mind appeal"

- Sandy Hill, Studio Hill Design, Albuquerque

"My clients are very impressed with the originality, timelessness and quality of David's art. His work is uniquely his own style and works so well in any environment. I am easily able to communicate with him as to my clients' needs and he never fails to deliver a design that is beautiful, appropriate, and on time."

- Lois B. Gries ASID, Past President, ASID Illinois

"Professionalism is the operative word in working with David Orth. His follow through and timeliness are admirable. As an interior designer, I appreciate the artistic integrity with which David adapts his designs to specific sites."

- Marilyn Davis, ASID - IIDA
Highland Park, IL

"... really occupies that space between 'what is furniture?' and 'what is art?' Really very, very beautiful work."

- Victoria Lautman for Chicago Public Radio

"Good work."

- Walter A. Netsch, American architect

"Serious design."

- Ruth Duckworth, American sculptor

"Holy Cow."

- Kerry Aufderheide, Blue Table Studio

Orth Sculpture & Furniture

Longtime Chicago artist DAVID ORTH now works from his home & studio in northwest Arkansas. He produces functional and non-functional work, most of it defying such simple categorizing. The work juxtaposes handcraft, industrial process, and exquisite materials - unfolding into a world of unusual beauty and intellectual challenge. His 30 years of critically acclaimed work is scattered across the country in public and private places.

Portfolio #1

Bronze & Steel / Tables & Pedestals by David Orth

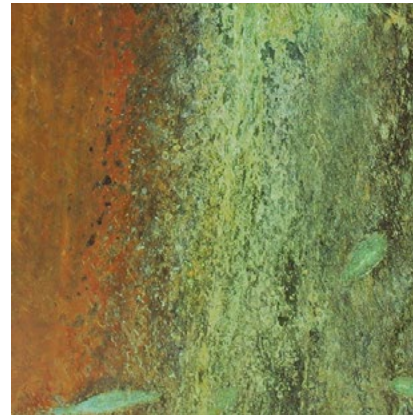

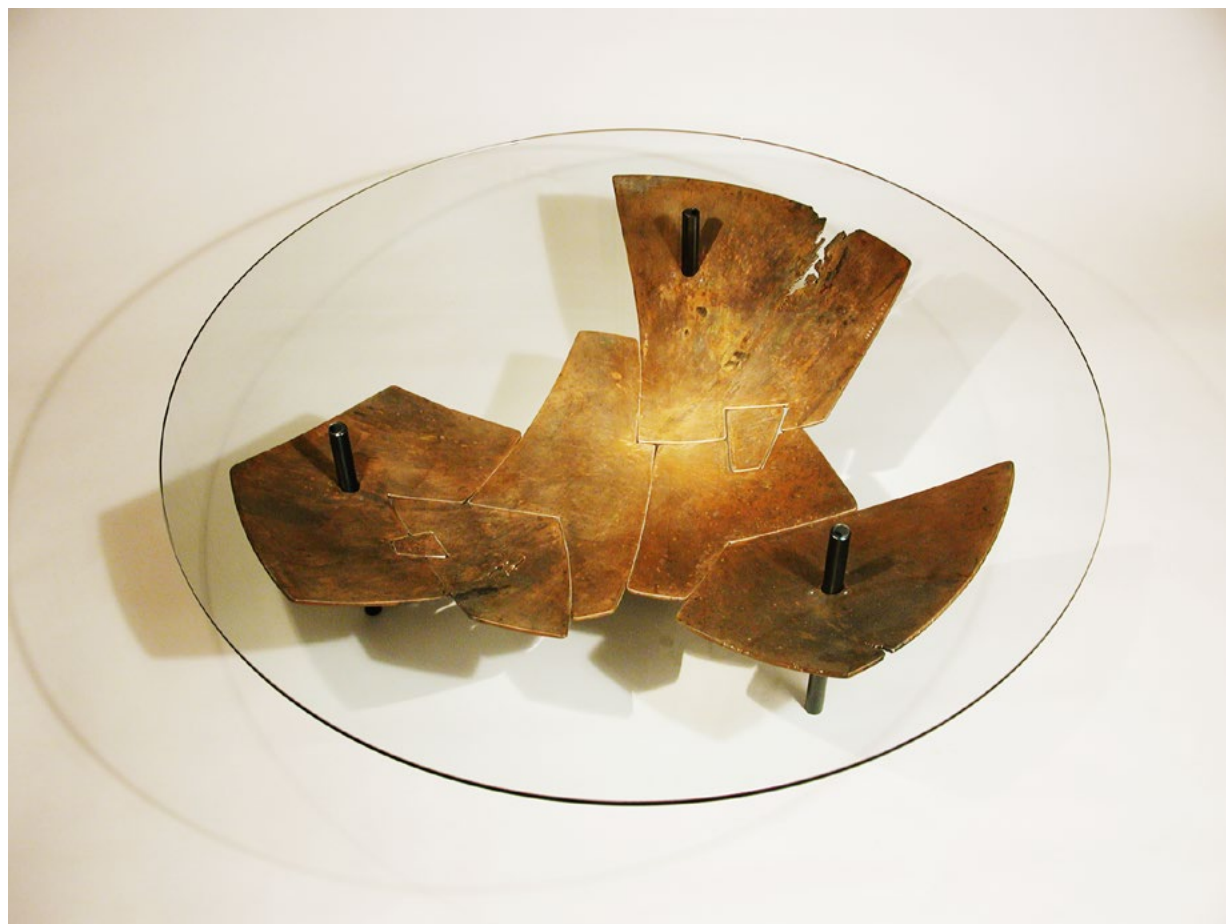
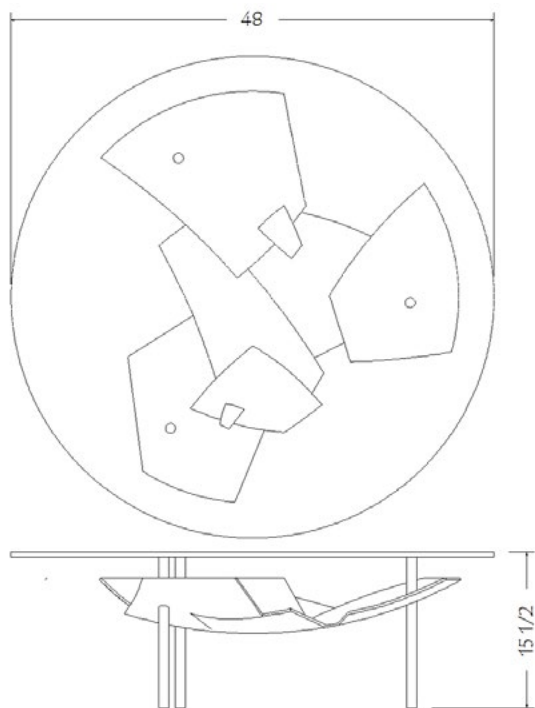

Aegean Table - #6902

Materials: Copperplate, Brassplate, or Steel

Size Shown: 48 diameter x 15H

Functions: coffee table or, with minor adaptation, a dining table

The main figure of this coffee table suggests a broken bowl of great archeological age. Pieces are missing. There are cracks and eroded edges in the heavy, quarter-inch thick bowl.

A heavy glass top is supported a couple of inches above the bowl shape.

The legs are blackened steel.



Pedestals (#7109 A through H)
More details on next page.



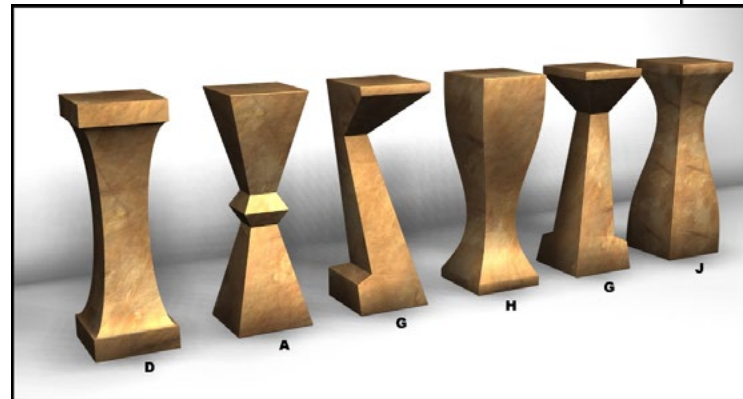
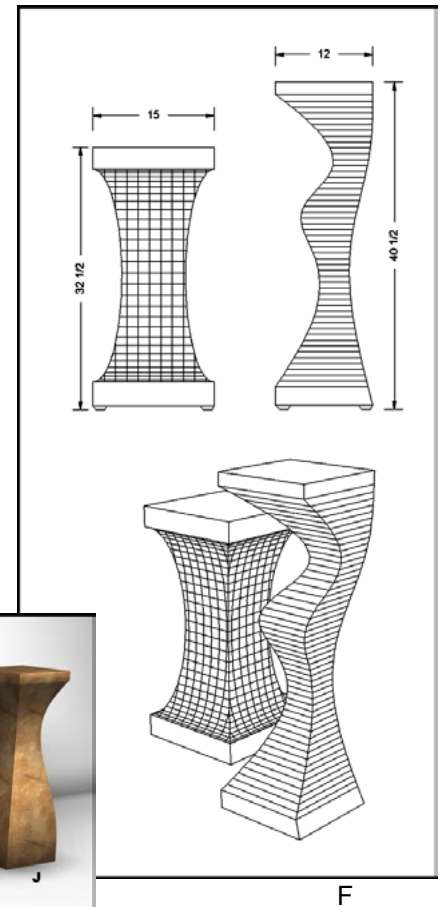
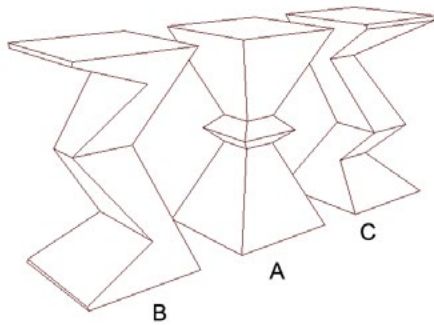
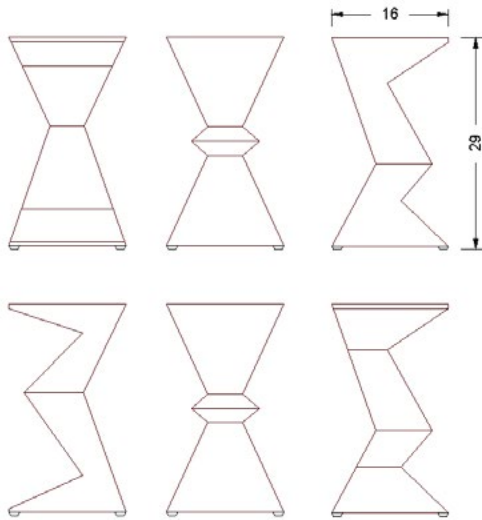

Continued from previous page:

Pedestals #7109 A through H

Materials: Bronze

Standard Size: Various, see line drawings.

Function: pedestal, accent table, or dining table

These pedestals suggest numerous combinations and applications. Custom designs and sizes. Glass tops available. One, two, or three in a row with glass becomes a dining table. One on its own is an end table or accent table.



alternative patina

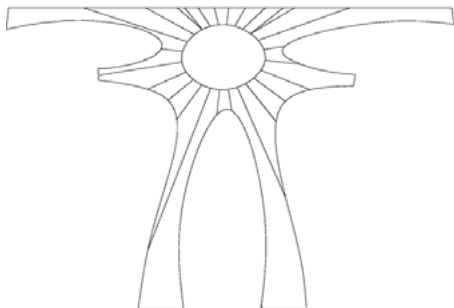
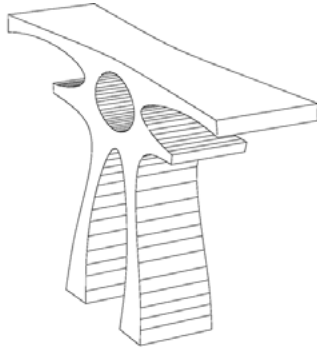

“Table of the Sun” - #7720

Materials: Bronze or steel

Size: to order

Function: console or entryway table

A sprightly console table invoking Native American sun pictographs & solar coronas. Note the line drawings which show the sculpted concavity of the face & back and the flared top surface. Shown in the dark classic bronze patina. An alternative look would be a light bronze finish as depicted in the detail.

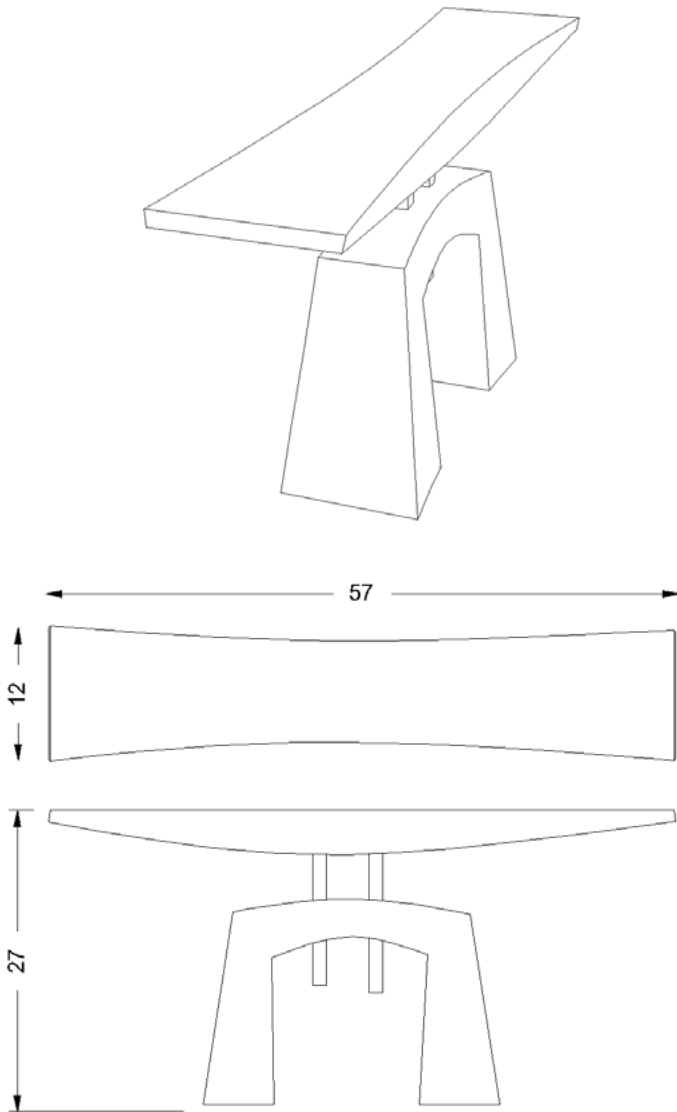

Cloud Mountain Table #7353

Materials: Bronze or Steel

Illustrated Size: 57W x 27H x 12D

Functions: sofa/console/entryway/meditation table

*Two simple shapes - cloud & mountain,
mind & body, branch & root.*

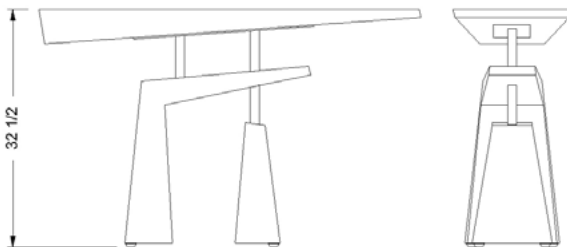
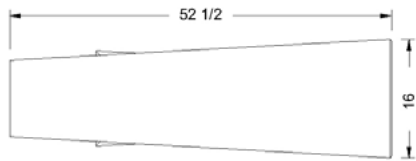
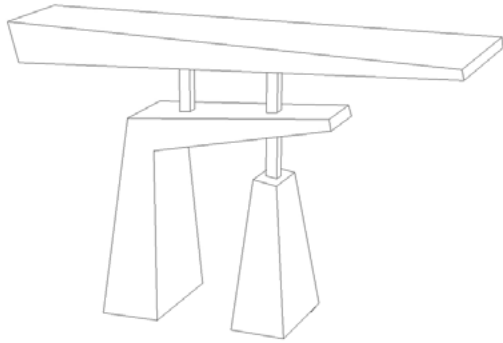

Glyph Table #7430
Materials: Bronze or Steel
Illustrated Size: 52.5W x 32.5H x 16D
Function: console table

Brisk and energetic - as if sketched in air.

Custom sizes & patinas available.



Clapp Table #7441
Materials Shown: Bronze, Walnut, & Steel
Size Shown: 140W x 33H x 18W

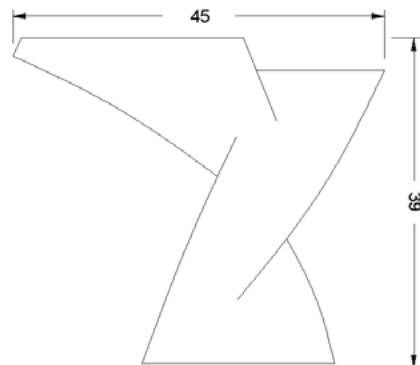

Tempest Table #7356

Materials: Bronze or Steel

Size Shown: 45W/39H/15D

This lyrical console table has two level surfaces at different heights. Mass & fluidity. Vital energy frozen in time. Custom sizes, materials, & patinas available.

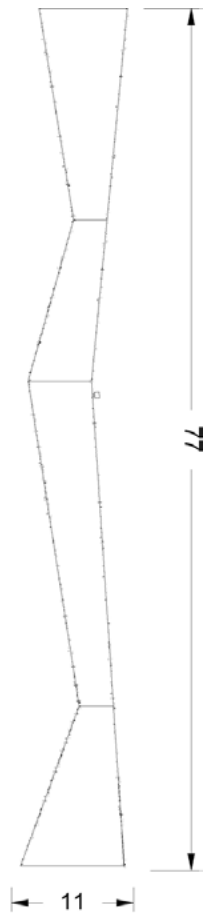

Torchiere #7309
Materials: Bronze
Standard Size: 11W x 77H x 11D

This dramatic torchiere shines an adjustable beam to the ceiling, casting a delicate glow over a room.



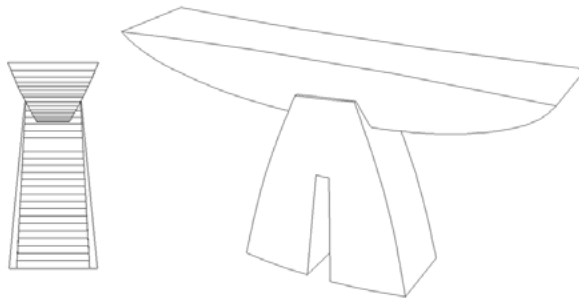
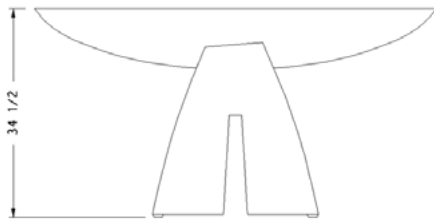
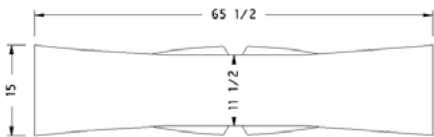

Inca Side Table #7324

Materials: Bronze or steel

Size shown: 65.5W x 34H x 15D (custom sizes available)
This console table was partially inspired by the closely fitting stones of Machu Picchu.

sculpted concrete base with alternative steel top



optional raindrop detail

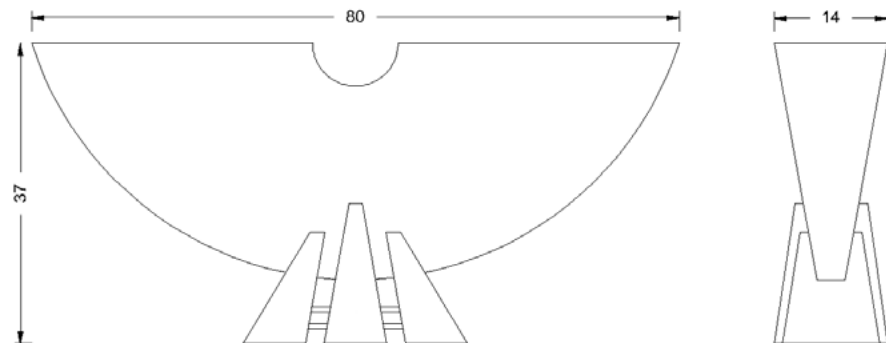

Eclipse Table #7341

Materials: Bronze or Steel, & Sculpted Concrete

Typical Sizes: 60-80W x 34-38H x 12-14D

Function: console table or entryway table.

An enigmatic wedge of bronze or steel caught firmly in a stony base. This table has a strong, balanced presence - earthy & mystical, industrial & tribal. The base is buff-tone, textured, & waxed concrete. Custom sizes & colors available.

Options: incised "raindrop" details in bronze.



Detail with alternative patina.

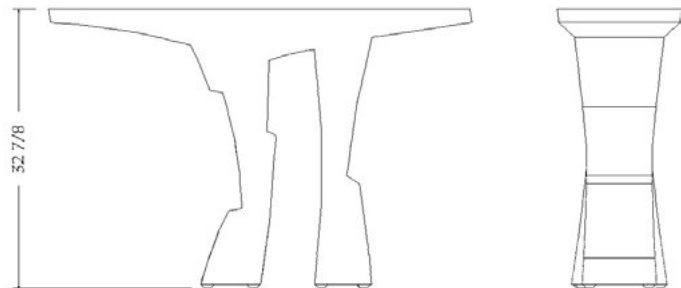
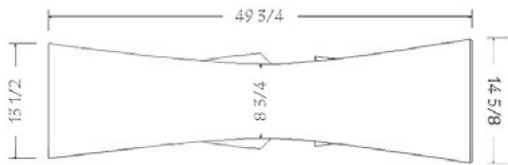

Pi Table #7325
Material: Bronze or Steel
Illustrated Size: 50W x 33H x 15D
Function: console table

*This table reminds me of Stone Henge.
It reminds me of a heavy draft horse.
It reminds me of the symbol Pi.
It reminds me that I love tables.*



Chapel Furnishings for Bexley Seabury Theological Seminary
bronze & slumped glass

Episcopal seminary Bexley-Seabury needed a fresh visual approach for a new space & chapel. We wanted something paradoxical: both modern & ancient, substantial yet resilient, contemplative and active. After considerable conversation, we chose simple Tree of Life forms to carry all these polarities forward in a deep balance. Installed Easter 2012.

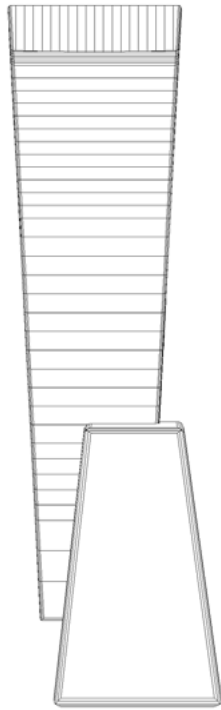

Typical Side View



Bird Tables #7350
Materials: *Bronze or Steel & Sculpted Concrete*
Size: *various*
Function: *console table, serving table.*

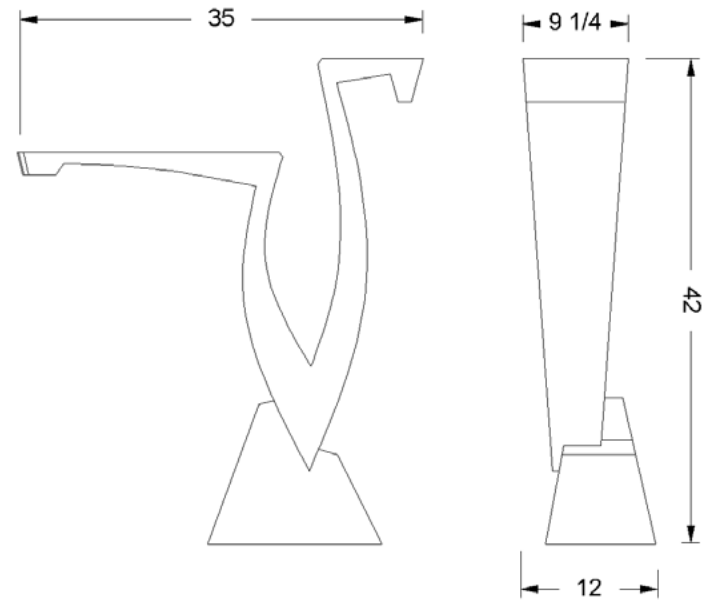

Bird Pedestal #7337

Materials: Bronze or Steel, & Sculpted Concrete

Illustrated Size: 35W x 42H x 12D

Function: entry table, console table, or sculpture

This sculpture/table is sister to Bird Table #7350 and is perfect for a vase of flowers, special objects, or nothing at all. The base is sculpted, waxed concrete with a buff, stone-like finish.

Custom sizes & reversed profile available.

Einstein's Table - #5922
Materials Shown: Blued Steel
Size Shown: 42W x 15H x 39D

Coffee table with no "parts" - just a warped singularity.
An exploration of continuous form.



Meteorite Coffee Table - #5912
Raw oxidized steel with patina
Size Shown: 48Diameter x 15H

This coffee table starts with a massive,
expansive steel bowl.
Dining table version available.

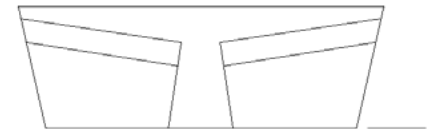
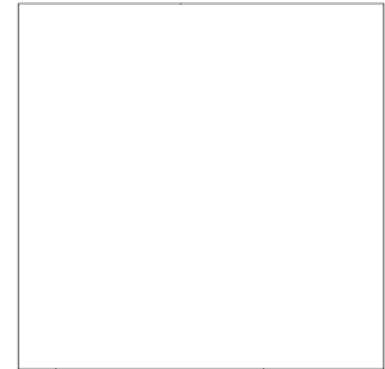
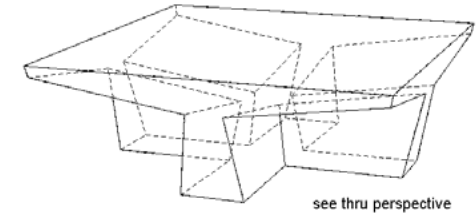

Tau Coffee Table #7343

Materials: Bronze or Steel

Size: To order

Simple, cantilevered elegance. This basic structure lends itself to many shapes & sizes.

Baobab Table #7704
Materials: Bronze or Steel
Size Shown: 37.75W x 40H x 14D
Function: pedestal/console table

This little idiosyncratic table is perfect for a nook or an entryway.

Custom sizes, materials, & patinas available.

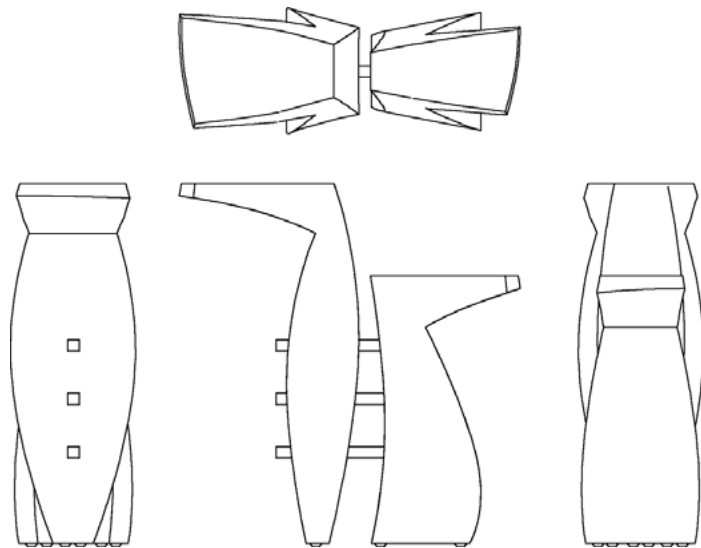

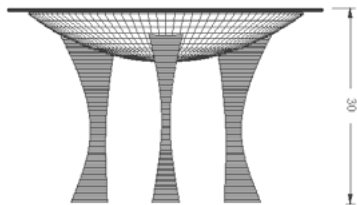
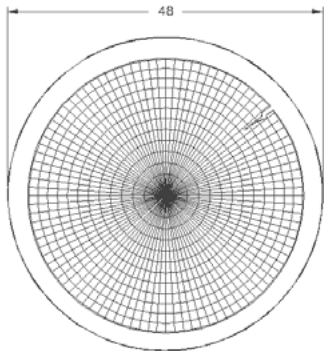
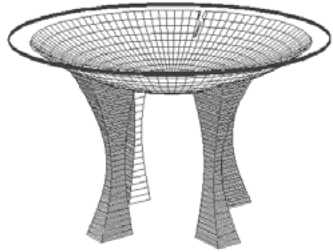

Bowl Table #7344

Materials: Copperplate, Brassplate, or Steel

Standard Size: 48 Diameter x 30H

Function: dining/library/game table

*This table is formed of a generous, perfectly shaped bowl.
Bowls such as this emanate a dramatic, mystical presence that draws you in.*

The bowl may be left empty or used as a sand/rock/shell garden.

*Dinner parties have been known to remove the glass top after a meal
and sit around for hours inventing ever-new arrangements in the sand.*

Realistic cracks and weathering in the metal suggest an object of archeological age.



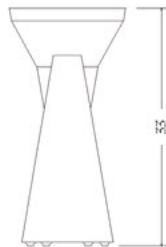
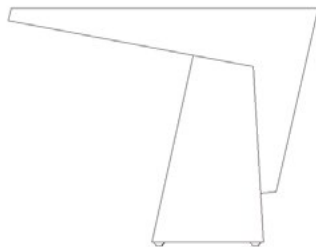
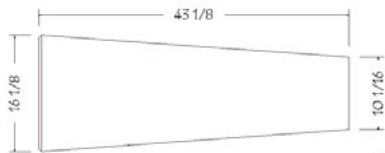
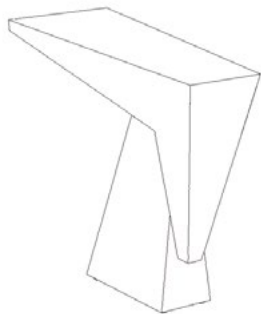

Table Constellation #7437
Materials: Bronze or Steel
Illustrated Size: 43W x 33H x 16D
Function: console table

Bronze Patina Selection

A sampling of patina options for bronze.

Standard Finishes



Light Classic



Medium Classic



Dark Classic

Verdigris Custom Finishes



The Steel Alternative

Steel is a beautiful, affordable alternative to bronze and copper and is available for all metal designs. These alternatives are made with the same craftsmanship and functionality as bronze. Choose from several breathtaking steel patinas or enamel coatings. Pictured here are just a few of the possibilities.



oxide - verdigris detail optional

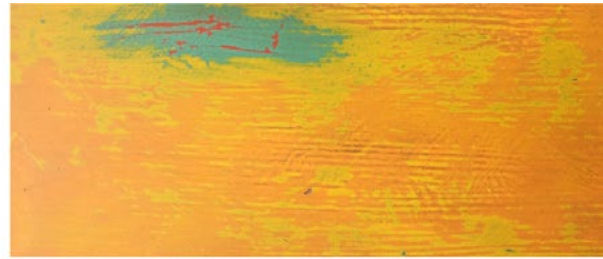

acrylic sunburst



dark steel

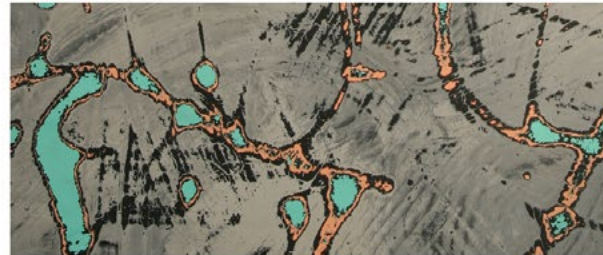

acrylic planet



feathered steel



hammered nickel

DETAILING OF BRONZE & STEEL

Detailing can contribute a sense of time, soulfulness, & distinction to a project. I apply details in random, careful touches to suggest natural processes such as raindrops, lichen, or weathering. Organic, sparing details do not distract from the overall form, but add depth, complexity, and feeling.



*You have just viewed portfolio #1 - bronze & steel furnishings.
More furniture & sculpture in woods and metals at
OrthSculpture.com*

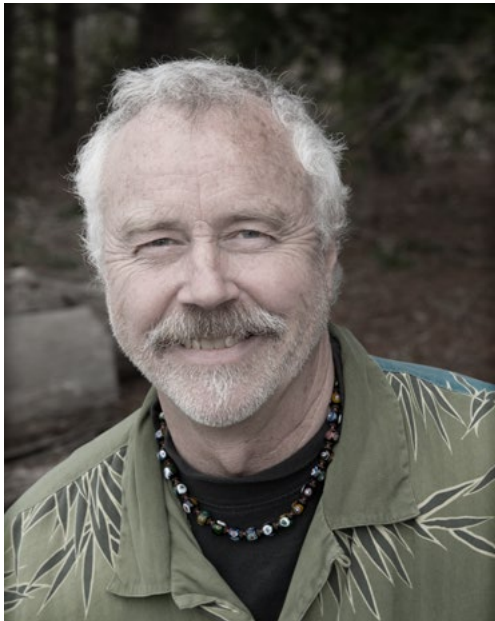

David Orth
photo credit: Diane Drake